

M12 x 1.75 THREAD x 1.25 DEEP
 C'BORE DIA .515 x .230 DEEP

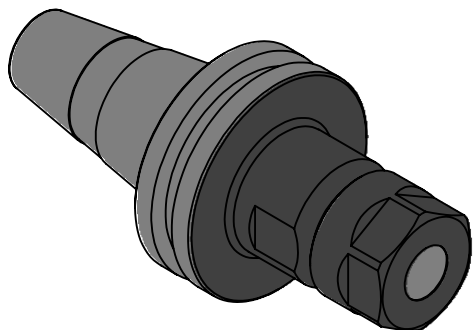
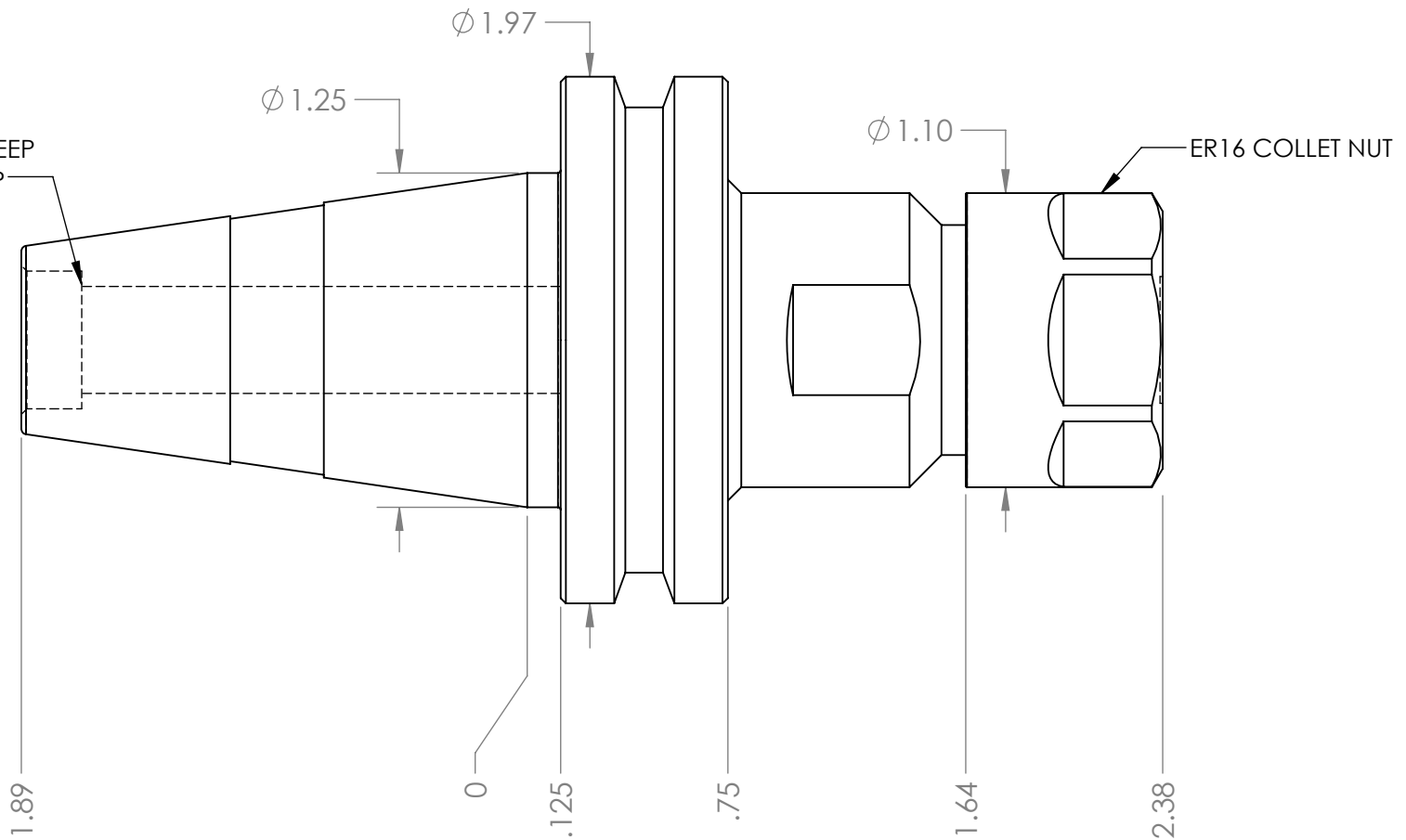

NOTES:
 WORKS ON ALL ISO30 MACHINES
 ACCEPTS ALL ER16 COLLETS FROM .039"-.4375"
 USES WRENCH PART # ER16-WRENCH (NOT INCLUDED)
 FOR MORE PRODUCT DETAILS PLEASE GO TO MARITOO.COM
 AND SEARCH ITEM # LISTED ON THIS PRINT

MARITOO

WWW.MARITOO.COM

ITEM# **ISO30 ER16-60**

Made in USA